

# User manual

## Resistance thermometer WTR 110



Version 3.2.1

**Content**

1. General.....	4
1.1 Description of measuring principle.....	4
1.2 Overview presentation.....	4
1.3 Drawings, shortcut.....	5
2. Transport, Packaging, Storage.....	5
2.1 Transport.....	5
2.2 Packaging.....	5
2.3 Storage.....	5
3. Safety instructions .....	6
3.1 Intended use of the product.....	6
3.2 Stuff qualification .....	6
3.3 Special hazards .....	6
4. Starting operation .....	7
4.1 Connection WTR 110 passive (ceramic base) .....	7
4.2 Connection WTR 110 with measuring transducer .....	8
4.3 Connection WTR 110 with M12 plug .....	8
4.4 Mechanical assembly .....	8
4.5 Electrical assembly.....	9
5. Operation.....	9
5.1 Configuration DMU 100 .....	9
5.1.1 Windows software „pmtKonfigTool“ .....	9
5.1.2 pmtKonfigTool - connection between WTR 110-DMU and PC.....	10
5.1.3 pmtKonfigTool – read.....	10
5.1.4 pmtKonfigTool – write .....	11
5.1.5 pmtKonfigTool – factory settings.....	11
5.1.6 Status.....	11
5.1.7 Temperature .....	11
5.1.8 Display .....	11
5.1.9 Fault current.....	12
5.1.10 4..20mA current output .....	12
5.2 Configuration KMU 100 .....	12
5.2.1 Windows Software „PXU01“.....	12
5.2.2 „PXU01“ – connection between WTR 110-KMU and PC .....	12
5.3 Configuration KMUS 100.....	13
	2

5.3.1	Measuring range selection by DIP-switch .....	13
5.3.2	Fine adjustment by correction potentiometer .....	14
6.	Technical specifications.....	14
6.1	Technical data DMU 100 .....	14
6.2	Technical data KMU 100 .....	15
6.3	Technical data KMUS 100.....	15
6.4	Technical drawing.....	17
7.	Dismounting, return, cleaning, disposal.....	19
7.1	Dismounting .....	19
7.2	Return.....	19
7.3	Cleaning .....	19
7.4	Disposal.....	19

## Resistance thermometer WTR 110

### 1. General

#### 1.1 Description of measuring principle

With our WTR 110 you have access to a device for use in temperature measurement in liquid and gaseous media. The integrated neck tube ensures decoupling from the process temperature, so that the sensor can be used reliably even at high temperatures. The simple replacement of the measuring insert makes this sensor ideal for use in closed processes. High-quality materials give this sensor a very long service life. The WTR 110 is also available passively or with the following measuring transducers:

- Digital measuring transducer DMU100 (4..20mA 3-wire/OLED display)
- Head transmitter KMU100 (4..20mA 2-wire)
- Head transmitter KMUS100 (0..10V 3-wire)

#### 1.2 Overview presentation

WTR 110-5-B-1A3-KMU-HT



WTR 110-1-B-1A3-KMU-HT



### 1.3 Drawings, shortcut



Warnung

#### **Warning!**

A non-observance can cause injuries to persons and/or the demolition of the device. There can be a dangerous to life.



#### **Attention!**

A non-observance can cause a faulty operation of the device or lead to property damage.



#### **Information!**

A non-observance can have influence on the operation of the device or cause unintentional reactions of the device.



Gefahr

#### **Danger!**

When not observing the safety instructions, there is a risk of serious or fatal injuries caused by electrical power.



Warnung

#### **Warning!**

Possibly a dangerous situation can occur, which results in burns because of hot surfaces or liquids, if not avoided.

## 2. Transport, Packaging, Storage

### 2.1 Transport

Check the instrument for any damage that may have been caused during transportation. If, report them immediately. The temperature during transportation and storage of the meter must be within the range of -10 °C to 50 °C.

### 2.2 Packaging

Do not remove packaging until just before mounting. Keep the packaging as it will provide optimum protection during transport (e.g. change in installation site, sending back).

### 2.3 Storage

For longer term storage avoid the following influences:

1. Direct sunlight or proximity to hot objects
2. Mechanical vibration, mechanical shock (putting it hard down)
3. Soot, vapour, dust and corrosive gases

If possible store the device in its original package or an equivalent one.

### 3. Safety instructions



More important safety instructions can be found in the individual chapters.

#### 3.1 Intended use of the product

The sensor has been designed and built solely for the intended use described here and may only be used accordingly. The technical specifications contained in these operating instructions must be observed. Improper handling or operation of the instrument outside of its technical specifications requires the instrument to be taken out of service immediately and an inspection by the manufacturer. When the instrument is transported from a cold into a warm environment, the formation of condensation may result in the instrument malfunctioning. Before putting it back into operation, wait for the instrument temperature and the room temperature to equalise. The manufacturer shall not be liable for claims of any type based on operation contrary to the intended use.

#### 3.2 Stuff qualification



Improper handling can result in considerable injury and damage to equipment. The activities described in these operating instructions may only be carried out by skilled stuff who have the qualifications described below. Keep unqualified stuff away from hazardous areas.

For installation and starting of the flow-meter the stuff has to be familiar with the relevant regulations and directives of the country and must have the qualification required. They must have knowledge on measurement and control technology, have to be acquainted with electric circuits, are capable of carrying out the work described and can independently recognize potential hazards. Depending on the operation conditions of the application they have to have the corresponding knowledge, e.g. of aggressive media.

#### 3.3 Special hazards



For hazardous media such as oxygen, acetylene, flammable or toxic gases or liquids, refrigeration plants, compressors, etc., in addition to all standard regulations, the appropriate existing codes or regulations must also be followed. **If you do not observe the appropriate regulation, serious injuries and/or damage can occur!**



A protection from electrostatic discharge (ESD) is required. The proper use of grounded work surfaces and personal wrist straps is required when working with exposed circuitry (PCB, printed circuit boards), in order to prevent static discharge from damaging sensitive electronic components.



There is a danger of death caused by electric current. Upon contact with life parts, there is a direct danger of death. Electrical instruments may only be installed and connected by skilled electrical personnel. Operation using a defective power supply unit (e.g. short circuit from the mains voltage to the voltage output) can result in life-threatening voltages at the instrument.



Residual media in dismantled instruments can result in a risk to personnel, the environment and equipment. Take sufficient precautionary measures. Do not use this instrument in safety or Emergency Stop devices. Incorrect use of the instrument can result in injury. Should a failure occur, aggressive media with extremely high temperature and under high pressure or vacuum may be present at the instrument.

## 4. Starting operation

### 4.1 Connection WTR 110 passive (ceramic base)

1 x PT 2-wire

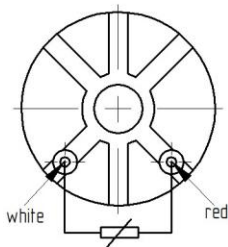

1 x PT 3-wire

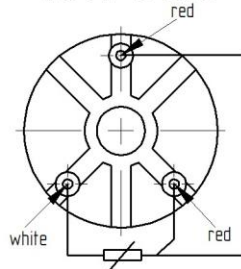

1 x PT 4-wire

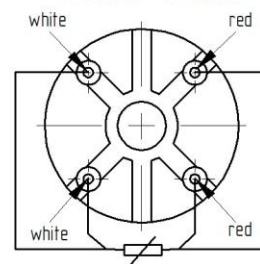

2 x PT 2-wire

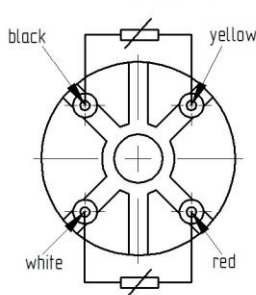

2 x PT 3-wire

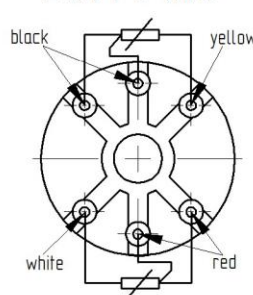

2 x PT 4-wire

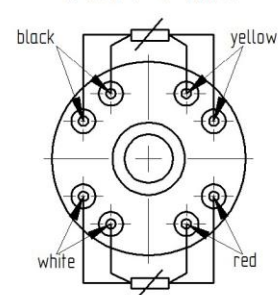

## 4.2 Connection WTR 110 with measuring transducer

### WTR 110 with KMU 100

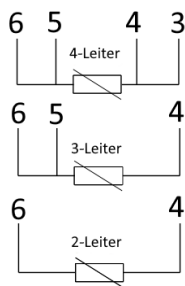
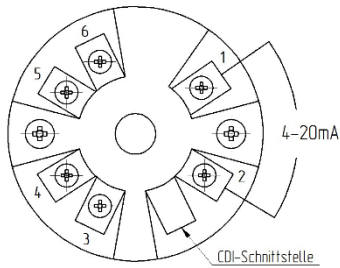

### WTR 110 with DMU 100

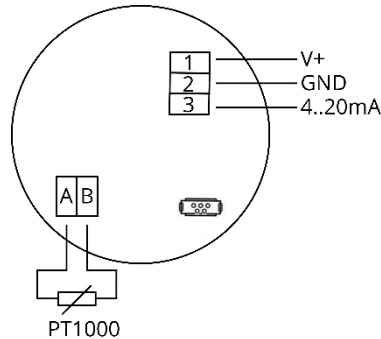

### WTR 110 with KMUS 100

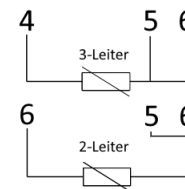
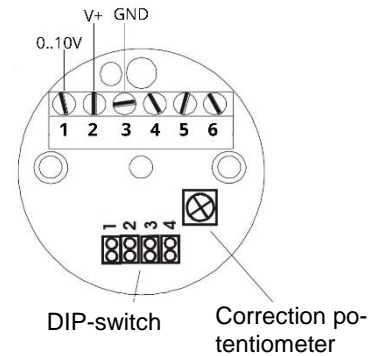

## 4.3 Connection WTR 110 with M12 plug

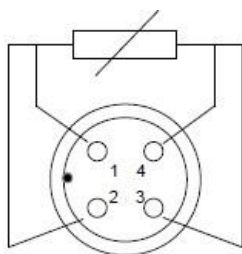

M12 plug  
 PT100 and PT1000

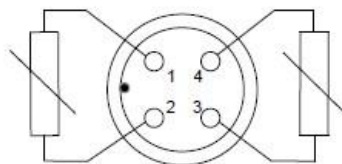

M12 plug  
 2x PT100 or 2x PT1000

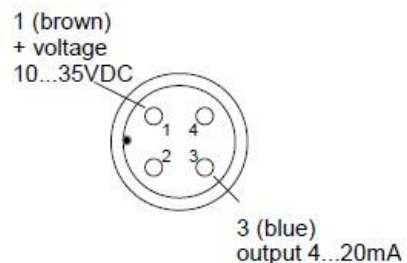

M12 connector with head transmitter

## 4.4 Mechanical assembly

- For adaptation in your process, only use the weld-in sockets and process connections from promesstec. This is the only way we can promise you an optimal measuring point.
- After installing the sensor, check the tightness of the measuring point.

## 4.5 Electrical assembly



The electrical installation must be carried out in a de-energized state.

### Connection with cable gland:

- Insert the connection cable into the cable entry (screw connection). Be careful not to damage the seal on the cable gland.
- Connect the connecting cables according to your circuit task.
- You can parameterize the device via the interface (DMU 100, KMU 100 or KMUS 100 measuring transducer option).
- Close the case and turn on the power.

### Connection with M12 connector:

- Screw the M12 socket onto the plug on the promesstec by hand
- Sensor. Assembly is carried out without tools.
- When installing the connection cable, ensure that it is firm and form-fitting
- Connection of both components. The permissible tightening torque can be found in the data sheet of the respective connection cable.

## 5. Operation



Before switching on the device, it should be checked whether the sensor has been correctly installed and wired.

### 5.1 Configuration DMU 100

If the WTR110 is used with a DMU100, the DMU settings can be read out, graphically displayed and changed using the Windows software “pmtKonfigTool”. The following explains how to configure the DMU with the “pmt-KonfigTool” software.

#### 5.1.1 Windows software „pmtKonfigTool“

The current settings of the DMU can be read out and changed via the "pmtKonfigTool" software. The installation file of the application can be downloaded from the website [www.promesstec.de](http://www.promesstec.de)

The configuration options include the display orientation, the scaling of the current output and the overflow and underflow behavior of the measuring range. In addition, the status, the measured value and the current value are read out in real time.

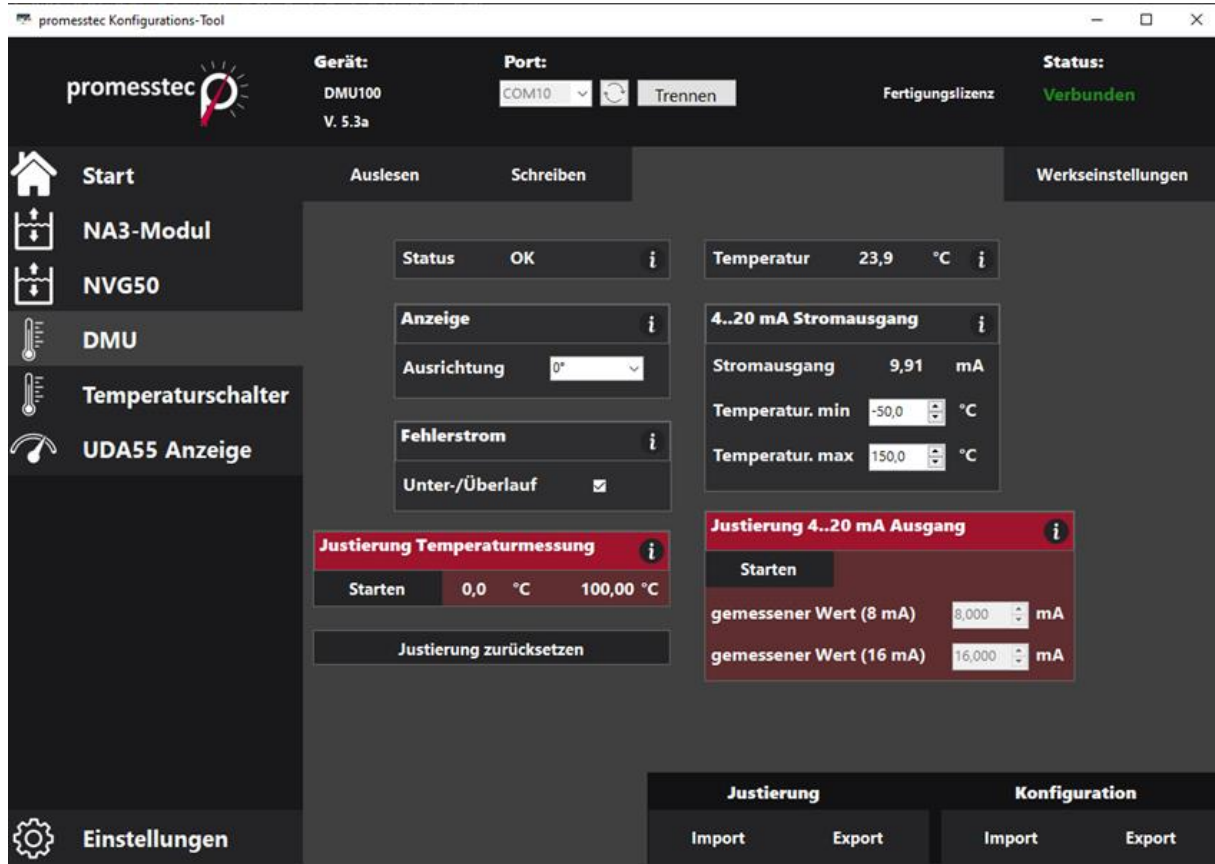

### 5.1.2 pmtKonfigTool - connection between WTR 110-DMU and PC

Loosen the cover of the WTR 110 to access the USB C interface of the DMU. Connect the transmitter to the PC using a standard USB C cable. ATTENTION: WTR 110 restarts after connecting via USB! Now start the Windows software “pmt-KonfigTool”.

To access the display, the correct COM port must first be selected. All COM ports are listed in the “Port” drop-down list. The button updates the drop-down list. As soon as a connection has been successfully established, the status changes to “Connected” and the name of the connected device is displayed.

### 5.1.3 pmtKonfigTool – read

As soon as a connection to the DMU has been established, the settings are read and displayed in the software. The status, temperature and current value are continuously updated. It is also possible to press the “Read” button to read and display all settings again.

#### 5.1.4 pmtKonfigTool – write

To change the DMU settings, the desired values must be entered into the Windows software and the appropriate options selected. However, the settings are only applied once the “Write” button has been pressed. If the writing process cannot be carried out successfully, the old DMU settings will be displayed again.

#### 5.1.5 pmtKonfigTool – factory settings

By pressing the "Factory settings" button, all parameters and settings are reset to the delivery state.

Factory settings:	display:	0°
	fault current:	activates
	MeasuringRangeMin.:	- 50,0 °C
	MeasuringRangeMax:	+150,0 °C

#### 5.1.6 Status

Overall, the DMU can assume four different statuses, which provide information about the current loop and the measurement of the current.

Ok:	the DMU is working properly.
Cable break:	there is a cable break in the connected PT1000.
Underflow:	the measured temperature is smaller than the smallest value that can be transmitted with the 4..20mA interface.
Overflow:	the measured temperature is greater than the largest value that can be transmitted with the 4..20mA interface.
Error evaluation:	there is an error in the evaluation of the PT1000.

#### 5.1.7 Temperature

Under the "Temperature" tab, the currently measured temperature is displayed in real time.

#### 5.1.8 Display

Under orientation, the orientation of the display can be rotated by 180°. The WTR 110-DMU can also be mounted overhead (cable exit upwards).

### 5.1.9 Fault current

The overflow and underflow function can be activated or deactivated using the “Underflow/Overflow” check box, which can be found under “Error current”. If the function has been activated, the DMU outputs a current of 20.5mA when the measured temperature exceeds the maximum temperature of the 4..20mA loop and 3.5mA when the measured temperature falls below the minimum temperature of the 4..20mA loop. If the function is deactivated, a current of 20mA and 4mA flows in the event of overshooting or undershooting. Regardless of the overflow and underflow function, a current of 21mA always flows if there is a cable break in the temperature sensor (PT1000).

### 5.1.10 4..20mA current output

Under the “4..20mA current output” tab, the current of the current loop is displayed in real time and the scaling of the loop is configured. To do this, the minimum temperature value for 4mA and the maximum temperature value for 20mA must be specified.

## 5.2 Configuration KMU 100

If the WTR 110 is used with a KMU 100, the settings of the KMU can be read and changed using the Windows software “PXU01”. The PXU01 parameterization software kit is required for this. This contains the Windows software “PXU01” on CD, an interface converter (USB adapter) and a plug adapter for the SME. The following explains the configuration of the SME with the “PXU01” software.

### 5.2.1 Windows Software „PXU01“

The current settings of the KMU can be read and changed using the “PXU01” software. The application installation file is provided via a CD or optionally via a download link. To receive the link, contact promesstec GmbH.

The configuration options include, among other things, scaling the current output. In addition, the measured value is read out in real time.



### 5.2.2 „PXU01“ – connection between WTR 110-KMU and PC

Loosen the cover of the WTR 110 to access the programming interface of the KMU. Connect the SME to the PC using the plug adapter and interface converter included in the PXU01 parameterization software kit.

In order to access the device, a connection must first be established in the application. The KMU settings can then be read and changed.

### 5.3 Configuration KMUS 100

The KMUS 100 is configured using a potentiometer and four DIP switches. Configuration on the PC is not necessary.

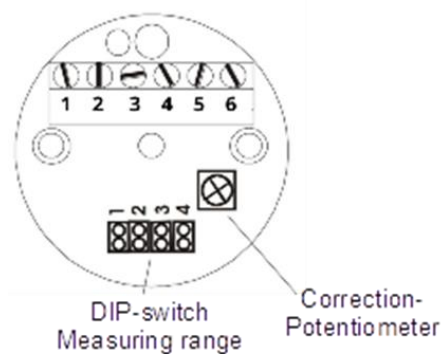

#### 5.3.1 Measuring range selection by DIP-switch

Four DIP-switches can be used to set 12 different measuring ranges. These are listed in the table below.

The query for the measuring range is permanent. Thus, the voltage supply does not have to be interrupted after a change of the measuring range. The recognition of the sensor (Pt 100/Pt 1000) is also done automatically during operation.

**Attention:** For Pt 1000 only the ranges 1..5 are available.

Nr.	Messbereich	DIP-Sch.			
		1	2	3	4
MB1:	- 20°C .. +150°C	1	1	1	1
MB2:	0°C .. + 50°C	0	1	1	1
MB3:	0°C .. +100°C	1	0	1	1
MB4:	0°C .. +200°C	0	0	1	1
MB5:	0°C .. +300°C	1	1	0	1
MB6:	0°C .. +400°C	0	1	0	1
MB7:	0°C .. +500°C	1	0	0	1
MB8:	0°C .. +600°C	0	0	0	1
MB9:	- 50°C .. + 50°C	1	1	1	0
MB10:	-100°C .. +100°C	0	1	1	0
MB11:	- 30°C .. + 70°C	1	0	1	0
MB12:	- 40°C .. + 60°C	0	0	1	0

Jumper = 1: plugged  
 Jumper = 0: not plugged

### 5.3.2 Fine adjustment by correction potentiometer

As can be seen in the image above, the correction potentiometer is located on the upper side of the KMUS. This can be used to fine-tune the output voltage. A seal secures the potentiometer against accidental adjustment.

## 6. Technical specifications

Protective fitting made of stainless steel 1.4571  
 Diameter 9 x 1 mm, other diameters on request  
 Process connection thread G 1/2"A, others on request  
 Operating temperature: -50 °C to +400 °C (extended ranges on request)  
 Deviation in operating temperature when using a transmitter

### 6.1 Technical data DMU 100

Operating temperature:	-30 °C..+70 °C
Operating voltage:	UB = 10..35 V DC
Current requirement:	7.3 mA (UB=24V) + 4..20mA output
Input:	PT1000 2-wire
Measuring range max.:	-100°C..+650°C
Measuring span min.:	10 K
Measuring deviation:	<+-0.1% of the final value
Output:	4..20mA 3-wire (underflow 3.5mA, overflow 20.5mA)
Sensor break:	21mA
Standard configuration:	4mA = -50°C, 20mA = 150°C

Max. permissible load:	(wide temperature range can be parameterized) $R_{max} = [(UB - 6V) / 0.021 A] \Omega$
Display:	high-resolution OLED display 0.96 inches
Orientation display:	0° or 180°
Display digits:	4 digits
Display range:	-99.9 to +999.9°C
Configuration interface:	USB Type C
Electrical connection:	6 screw terminals 1.5mm <sup>2</sup>
Configuration:	commercially available USB C cable (no programming adapter necessary) Windows application for configuration ("pmt-Konfig-Tool")

## 6.2 Technical data KMU 100

operating temperature:	-40 °C..+85 °C
operating voltage:	UB = 10..36VDC
current requirement:	4..20mA output
input:	PT100 or PT1000 2, 3, 4 wire
measuring range max.	Pt100: -200°C..+850°C; Pt1000: -200°C ... +250 °C
measuring span min.:	10 K
measuring deviation:	across the entire range: 0.15 K or 0.07% of span* in the range -50°C ... +250°C: 0.1 K or 0.07% of the measuring span*
output:	4-20mA (underflow linear drop of 4.0 ... 3.8 mA, linear increase of 20.0 ... 20.5 mA)
sensor break:	≤ 3.6 mA ("Low") or ≥ 21 mA ("High") can be selected
standard configuration	4mA = -50°C, 20mA = 150°C (wide temperature range can be parameterized)
electrical connection:	6x screw terminals 1.5mm <sup>2</sup>
configuration:	PXU01 programming adapter Windows application for configuration ("PXU01")

\* the larger value is valid

## 6.3 Technical data KMUS 100

Operating temperature:	-40 °C ..+85 °C
Operating voltage:	UB = 15..35 V DC
Current requirement:	max. 10mA
Input:	PT100/PT1000 2, 3, 4 wire

Measuring range:	12 measuring ranges, see page 3
Measuring deviation:	<+-0.3% of measuring range
Output:	0..10V 3-wire
Sensor break:	>10V
Standard configuration:	0V = -20°C, 10V = 150°C
Electrical connection:	5x terminal connection 1.5 mm <sup>2</sup>
Configuration:	DIP switch (12 different measuring ranges)

## 6.4 Technical drawing

### WTR 110 stainless steel connection head

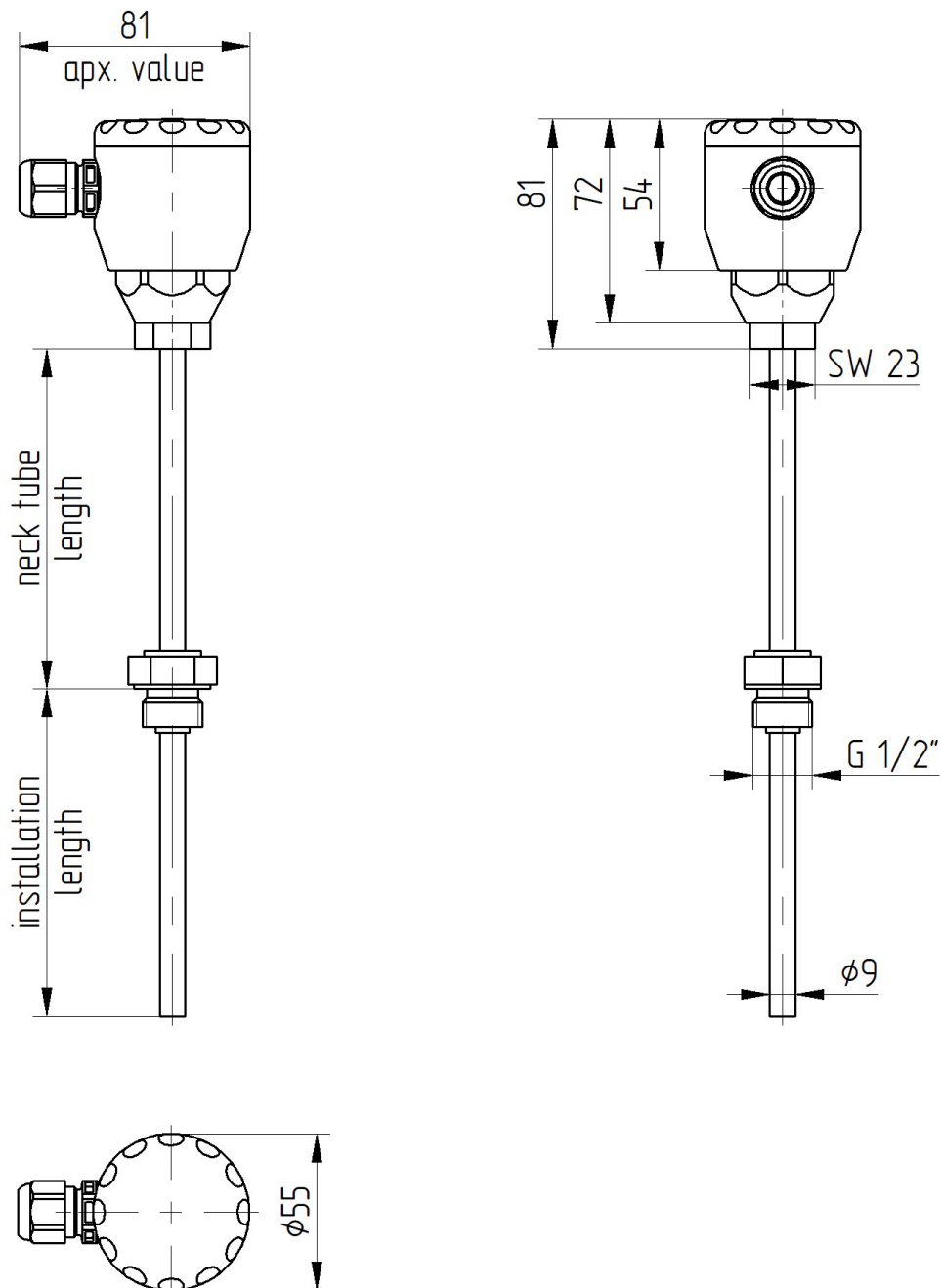

WTR 110 aluminum connection head

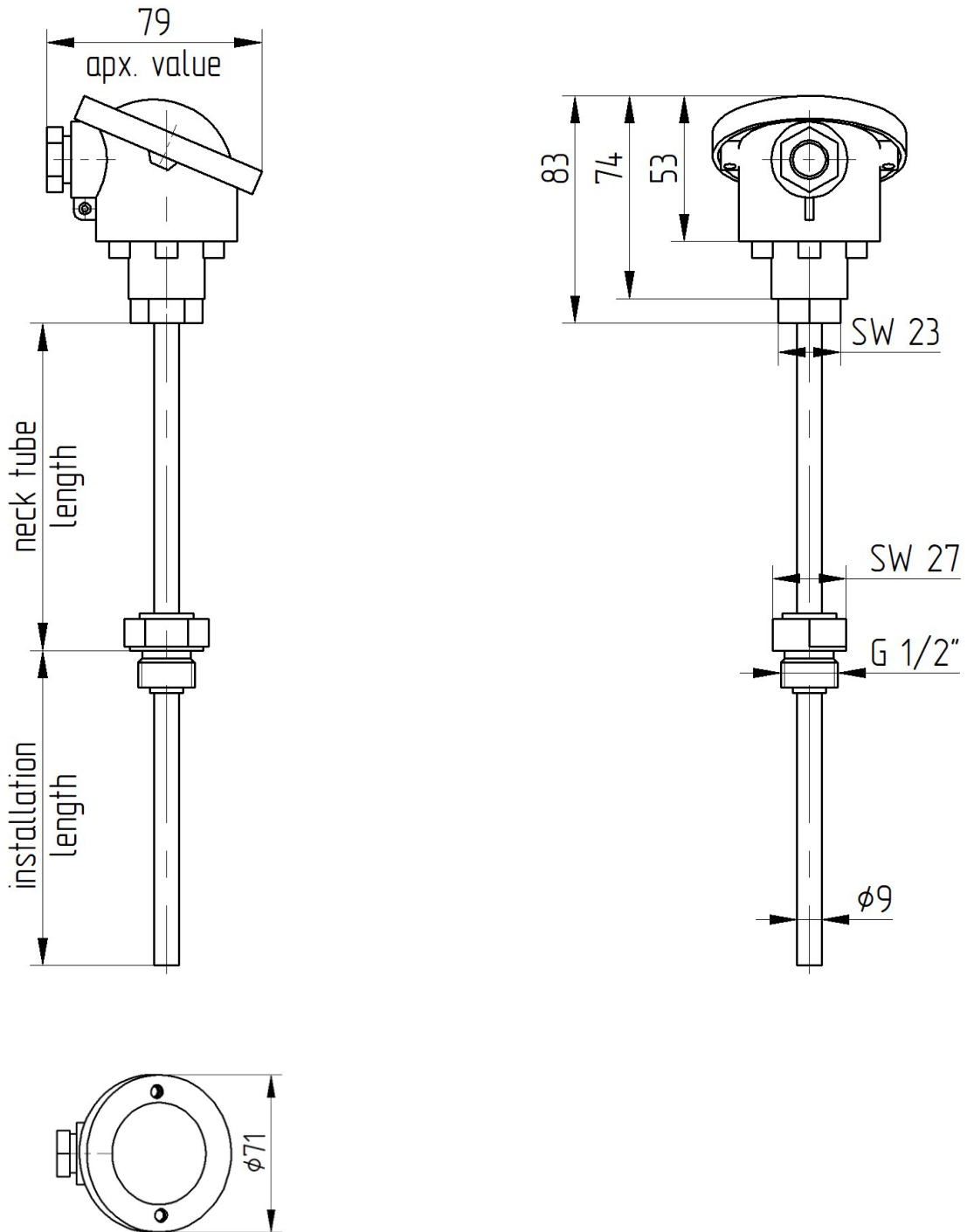

## 7. Dismounting, return, cleaning, disposal

### 7.1 Dismounting



Residual media in dismantled instruments can result in a risk of personnel, the environment and equipment. Take sufficient precautionary measures.



There is a risk of burns. Let the instrument cool down sufficiently before dismantling. During dismantling there is a risk of dangerously hot pressure media escaping.

Only disconnect the resistance thermometer once the system has been depressurised.

### 7.2 Return

To return the device, use the original packaging or something similar. To protect against damage, e.g. antistatic film, insulating material, marking can be used as a sensitive measuring device. Find out about the return process at [www.promesstec.de](http://www.promesstec.de) and note the "return form" or contact our product support:

promestec GmbH  
Niedersachsenstraße 4  
48465 Schüttorf  
Tel.: 05923 902290  
[office@promesstec.com](mailto:office@promesstec.com)

### 7.3 Cleaning



Before cleaning the instrument disconnect the electrical connection. Clean the instrument with a moist cloth. Electrical connections must not come into contact with moisture. Wash or clean the dismantled instrument before returning it in order to protect personnel and the environment from exposure to residual media.

Residual media in dismantled instruments can result in a risk to persons, the environment and equipment. Take sufficient precautionary measures.

### 7.4 Disposal



This device is not subject to the **WEEE Directive 2012/19/EU** and the corresponding national laws. Take the device directly to a specialized recycling company and do not use the municipal collection points. These may only be used for privately used products in accordance with the WEEE directive. Proper disposal avoids negative

effects on people and the environment and enables valuable raw materials to be reused.