

User manual

Resistance thermometer WTR 230



Version 3.1.1

Content

1. General.....	4
1.1 Description measuring principle.....	4
1.2 Overview representation.....	4
1.3 Drawings, shortcut.....	5
2. Transport, Packaging, Storage.....	5
2.1 Transport.....	5
2.2 Packaging.....	5
2.3 Storage.....	5
3. Safety instructions.....	6
3.1 Intended use of the product.....	6
3.2 Stuff qualification.....	6
3.3 Special hazards.....	6
4. Starting operation.....	7
4.1 Connection.....	7
4.2 Mechanical assembly.....	8
4.3 Electrical assembly.....	8
5. Putting into operation.....	9
5.1 Configuration DMU 50.....	9
5.1.1 Windows Software „pmtKonfigTool“.....	9
5.1.2 pmtKonfigTool - Connection between WTR 230 DMU and PC.....	10
5.1.3 pmtKonfigTool – read.....	10
5.1.4 pmtKonfigTool – write.....	10
5.1.5 pmtKonfigTool – factory settings.....	10
5.1.6 Status.....	10
5.1.7 Temperature.....	11
5.1.8 Display.....	11
5.1.9 Fault current.....	11
5.1.10 4...20mA Current output.....	11
5.2 Configuration KMU 100.....	12
5.2.1 Windows Software „PXU01“.....	12
5.2.2 “PXU01” - Connection between WTR 230 KMU and PC.....	12
6. Technical specifications.....	13
6.1 Technical data DMU 50.....	13
6.2 Technical data KMU 100.....	13
	2

6.3	Technical drawings	14
7.	Dismounting, Return, Cleaning, Disposal	15
7.1	Dismounting	15
7.2	Return.....	15
7.3	Cleaning	15
7.4	Disposal.....	15

Resistance thermometer WTR 230

1. General

1.1 Description measuring principle

The WTR 230 is a temperature sensor with a connection housing made of polyamide. The sensor is ideal as a duct sensor to reliably record temperatures in pipes and ducts. Thanks to the robust housing made of polyamide, the WTR 230 can also be used in aggressive environmental conditions in industry without any problems. The WTR 230 is available both passively and with the KMU 100 head transmitter, which has a 4..20mA output. The WTR 230 is also available with the DMU 50 measuring transducer. In addition to a 4..20mA output, the DMU has a high-resolution OLED display.

1.2 Overview representation

WTR 230-A1-A-1A3

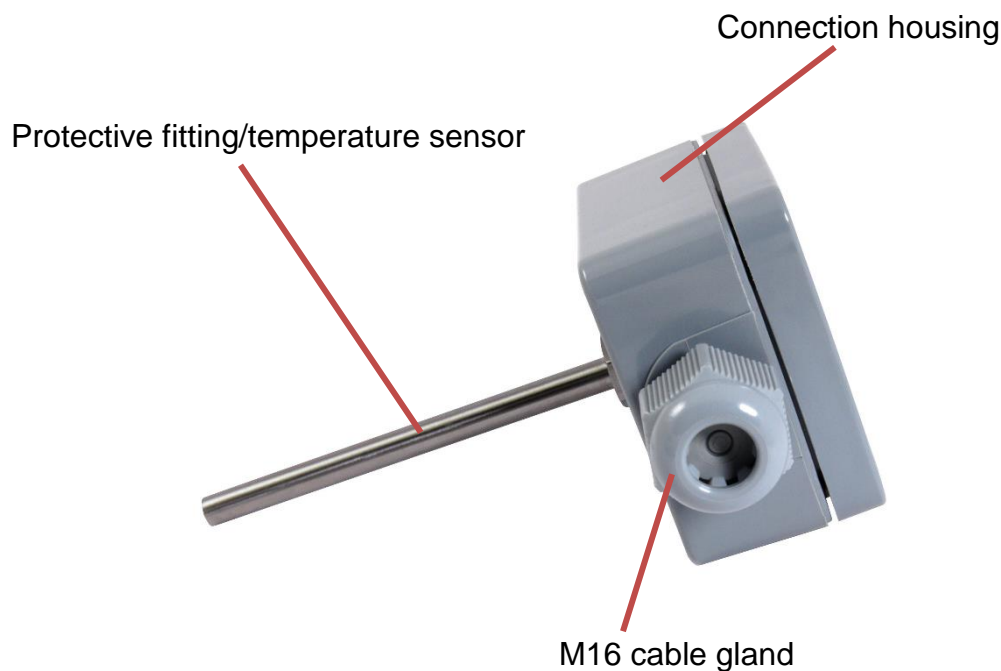

1.3 Drawings, shortcut



Warning!

A non-observance can cause injuries to persons and/or the demolition of the device. There can be a dangerous to life.



Attention!

A non-observance can cause a faulty operation of the device or lead to property damage.



Information!

A non-observance can have influence on the operation of the device or cause unintentional reactions of the device.



Danger!

When not observing the safety instructions, there is a risk of serious or fatal injuries caused by electrical power.



Warning!

Possibly a dangerous situation can occur, which results in burns because of hot surfaces or liquids, if not avoided.

2. Transport, Packaging, Storage

2.1 Transport

Check the instrument for any damage that may have been caused during transportation. If, report them immediately. The temperature during transportation and storage of the meter must be within the range of -10 °C to 50 °C.

2.2 Packaging

Do not remove packaging until just before mounting. Keep the packaging as it will provide optimum protection during transport (e.g. change in installation site, sending back).

2.3 Storage

For longer term storage avoid the following influences:

1. Direct sunlight or proximity to hot objects
2. Mechanical vibration, mechanical shock (putting it hard down)
3. Soot, vapour, dust and corrosive gases

If possible store the device in its original package or an equivalent one

3. Safety instructions



More important safety instructions can be found in the individual chapters.

3.1 Intended use of the product

The sensor has been designed and built solely for the intended use described here and may only be used accordingly. The technical specifications contained in these operating instructions must be observed. Improper handling or operation of the instrument outside of its technical specifications requires the instrument to be taken out of service immediately and an inspection by the manufacturer. When the instrument is transported from a cold into a warm environment, the formation of condensation may result in the instrument malfunctioning. Before putting it back into operation, wait for the instrument temperature and the room temperature to equalise. The manufacturer shall not be liable for claims of any type based on operation contrary to the intended use.

3.2 Stuff qualification



Improper handling can result in considerable injury and damage to equipment. The activities described in these operating instructions may only be carried out by skilled stuff who have the qualifications described below. Keep unqualified stuff away from hazardous areas.

For installation and starting of the flow-meter the stuff has to be familiar with the relevant regulations and directives of the country and must have the qualification required. They must have knowledge on measurement and control technology, have to be acquainted with electric circuits, are capable of carrying out the work described and can independently recognize potential hazards. Depending on the operation conditions of the application they have to have the corresponding knowledge, e.g. of aggressive media.

3.3 Special hazards



For hazardous media such as oxygen, acetylene, flammable or toxic gases or liquids, refrigeration plants, compressors, etc., in addition to all standard regulations, the appropriate existing codes or regulations must also be followed. **If you do not observe the appropriate regulation, serious injuries and/or damage can occur!**



A protection from electrostatic discharge (ESD) is required. The proper use of grounded work surfaces and personal wrist straps is required when working with exposed circuitry (PCB, printed circuit boards), in order to prevent static discharge from damaging sensitive electronic components.



There is a danger of death caused by electric current. Upon contact with live parts, there is a direct danger of death. Electrical instruments may only be installed and connected by skilled electrical personnel. Operation using a defective power supply unit (e.g. short circuit from the mains voltage to the voltage output) can result in life-threatening voltages at the instrument.



Residual media in dismantled instruments can result in a risk to personnel, the environment and equipment. Take sufficient precautionary measures. Do not use this instrument in safety or Emergency Stop devices. Incorrect use of the instrument can result in injury. Should a failure occur, aggressive media with extremely high temperature and under high pressure or vacuum may be present at the instrument.

4. Starting operation

4.1 Connection

WTR 230 passive

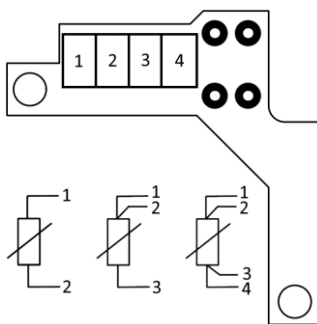

WTR 230 with DMU 50

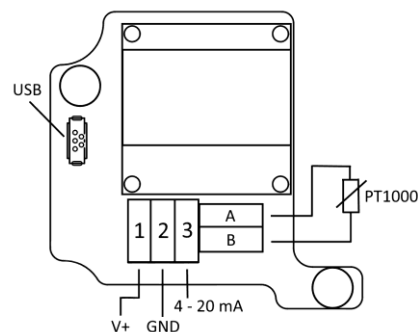

WTR 230 with KMU 100

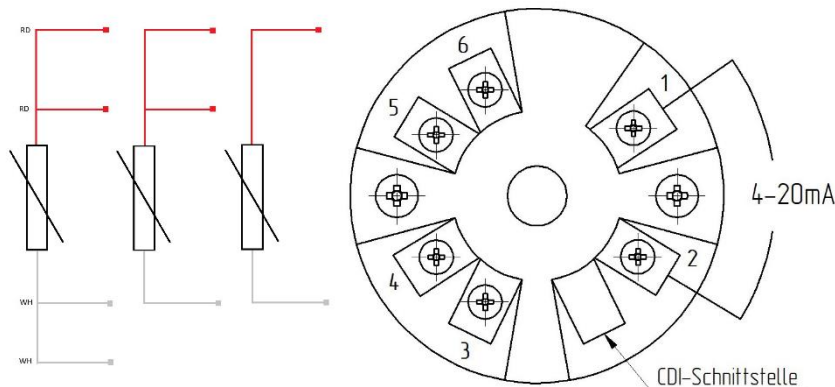

4.2 Mechanical assembly

- For adaptation in your process, only use the welded sockets and process connections from promesstec. This is the only way we can promise you an optimal measuring point.
- After installing the sensor, check the tightness of the measuring point.

4.3 Electrical assembly



Warnung

The electrical installation must be carried out in a de-energized state.

- Open the case
- Insert the connection cable into the cable entry (screw connection). Be careful not to damage the seal on the cable gland.
- Connect the connecting cables according to your task.
- If a measuring transducer is used, it can be configured via the respective interface.
- Screw the device cover back on and switch on the power.

After installing the sensor, check the tightness of the housing and after installing the connecting cable, check the tightness of the screw connection (cable entry).

5. Putting into operation



Before switching on the device, you should check whether the sensor has been installed and wired correctly.

5.1 Configuration DMU 50

If the WTR 230 is used with a DMU 50, the DMU settings can be read out, graphically displayed and changed using the Windows software “pmtKonfigTool”. The following explains how to configure the DMU with the “pmt-KonfigTool” software.

5.1.1 Windows Software „pmtKonfigTool“

The current settings of the DMU can be read and changed using the “pmtKonfigTool” software. The application installation file can be downloaded from the website www.promesstec.de.

The configuration options include, among other things, the display orientation, the scaling of the current output and the overflow and underflow behavior of the measuring range. In addition, the status, the measured value and the current value are read out in real time.

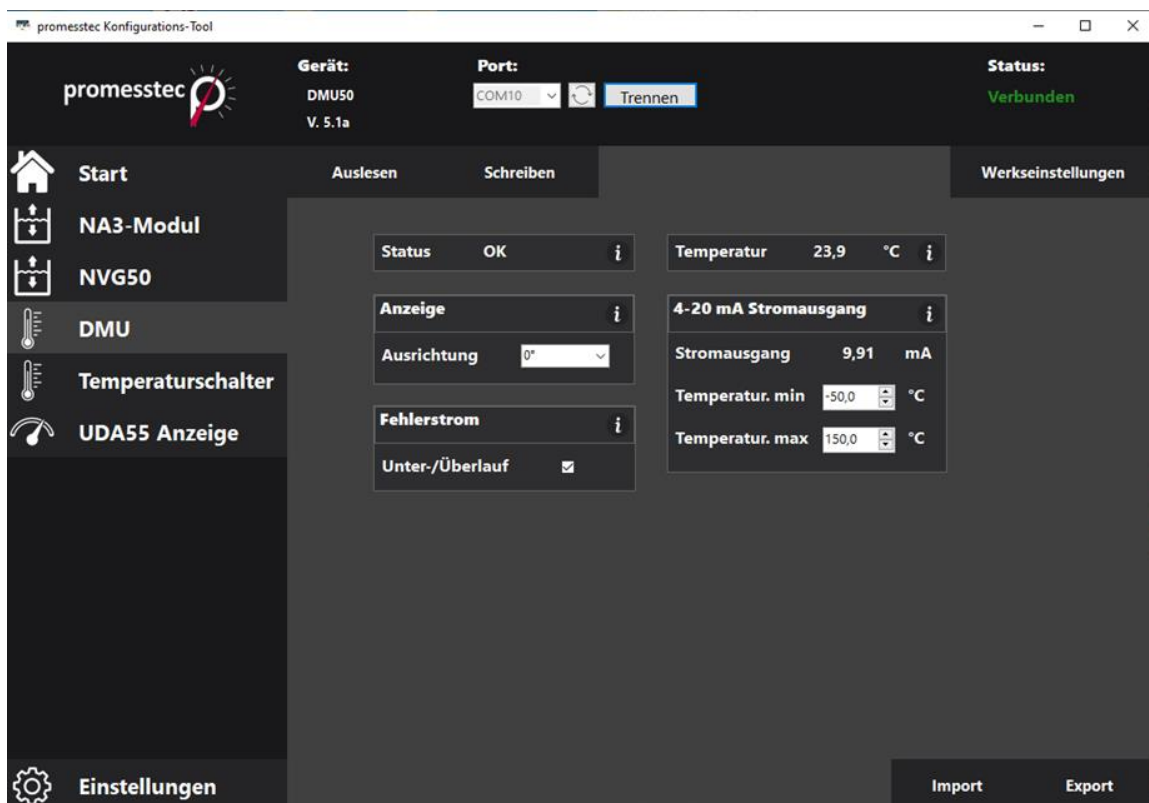

5.1.2 pmtKonfigTool - Connection between WTR 230 DMU and PC

Loosen the cover of the WTR 230 to access the USB C interface of the DMU. Connect the transmitter to the PC using a standard USB C cable.

ATTENTION: WTR 230 restarts after connecting via USB! Now start the Windows software “pmtKonfigTool”.

To access the display, the correct COM port must first be selected. All COM ports are listed in the “Port” drop-down list. The button updates the drop-down list. As soon as a connection has been successfully established, the status changes to “Connected” and the name of the connected device is displayed.

5.1.3 pmtKonfigTool – read

As soon as a connection to the DMU has been established, the settings are read and displayed in the software. The status, temperature and current value are continuously updated. It is also possible to press the “Read” button to read and display all settings again.

5.1.4 pmtKonfigTool – write

To change the DMU settings, the desired values must be entered into the Windows software and the appropriate options selected. However, the settings are only applied once the “Write” button has been pressed. If the writing process cannot be carried out successfully, the old DMU settings will be displayed again.

5.1.5 pmtKonfigTool – factory settings

By pressing the “Factory settings” button, all parameters and settings are reset to the delivery status.

Factory settings:	Display:	0°
	Fault current:	activated
	Measuring range min.:	-30.0 °C
	Measuring range max.:	+70.0°C

5.1.6 Status

Overall, the DMU can assume four different statuses, which provide information about the current loop and the measurement of the current.

Ok:	The DMU works perfectly
Cable break:	There is a cable break in the connected PT1000
Underflow:	The measured temperature is smaller than the smallest value that can be transmitted with the 4..20mA interface
Overflow:	The measured temperature is greater than the largest value that can be transmitted with the 4..20mA interface
Error evaluation:	There is an error in the evaluation of the PT1000

5.1.7 Temperature

The currently measured temperature is displayed in real time under the “Temperature” tab.

5.1.8 Display

Under Orientation, the orientation of the display can be rotated by 180°

5.1.9 Fault current

The overflow and underflow function can be activated or deactivated using the “Underflow/Overflow” check box, which can be found under “Error current”. If the function has been activated, the DMU outputs a current of 20.5mA when the measured temperature exceeds the maximum temperature of the 4..20mA loop and 3.5mA when the measured temperature falls below the minimum temperature of the 4..20mA loop. If the function is deactivated, a current of 20mA and 4mA flows in the event of overshooting or undershooting. Regardless of the overflow and underflow function, a current of 21mA always flows if there is a cable break in the temperature sensor (PT1000).

5.1.10 4...20mA Current output

Under the “4..20mA current output” tab, the current of the current loop is displayed in real time and the scaling of the loop is configured. To do this, the minimum temperature value for 4mA and the maximum temperature value for 20mA must be specified.

5.2 Configuration KMU 100

If the WTR 230 is used with a KMU 100, the settings of the KMU can be read and changed using the Windows software "PXU01". The PXU01 parameterization software kit is required for this. This contains the Windows software "PXU01" on CD, an interface converter (USB adapter) and a plug-in adapter for the SME. The following explains the configuration of the SME with the "PXU01" software.

5.2.1 Windows Software „PXU01“

The current settings of the SME can be read and changed using the "PXU01" software. The application installation file is provided via a CD or optionally via a download link. To receive the link, contact promesstec GmbH.

The configuration options include, among other things, scaling the current output. The measured value is also read out in real time.



5.2.2 "PXU01" - Connection between WTR 230 KMU and PC

Loosen the cover of the WTR 230 to access the programming interface of the KMU. Connect the KMU to the PC using the plug adapter and interface converter included in the PXU01 parameterization software kit.

In order to access the device, a connection must first be established in the application. The KMU settings can then be read and changed.

6. Technical specifications

Protective fitting material:	stainless steel 1.4571 (V4A)
Sensor length:	freely selectable
Connection housing:	plastic polyamide
Dimensions:	58 x 64 x 34 mm
Protection class:	IP 65 according to DIN 60529
Temperature range:	-50°C to +130°C (Deviation when using a measuring transducer)

6.1 Technical data DMU 50

Operating temperature:	-30 °C..+70 °C
Operating voltage:	UB = 10..35 V DC
Current requirement:	7.3 mA (UB=24V) + 4..20mA output
Input:	PT1000 2-wire
Measuring range max.	-100°C..+650°C
Measuring span min.:	10 K
Measuring deviation:	<+-0.1% of the final value
Output:	4..20mA 3-wire (underflow 3.5mA, overflow 20.5mA)
Sensor break:	21mA
Standard configuration:	4 mA = -40 °C, 20 mA = 70 °C (wide temperature range can be parameterized)
Max. permissible load:	$R_{max} = [(UB - 6V) / 0.021 A] \Omega$
Display:	high-resolution OLED display 0.96 inches
Orientation display:	0° or 180°
Display digits:	4 digits
Display range:	-99.9 to +999.9°C
Configuration interface:	USB Type C
Electrical connection:	6 screw terminals 1.5mm ²
Configuration:	Commercially available USB C cable (no programming adapter necessary) Windows application for configuration ("pmt-Konfig-Tool")

6.2 Technical data KMU 100

operating temperature:	-40 °C..+85 °C
operating voltage:	UB = 10..36VDC
current requirement:	4..20mA output
input:	PT100 or PT1000 2, 3, 4 wire
measuring range max.	Pt100: -200°C..+850°C;

measuring span min.:	Pt1000: -200°C ... +250 °C
measuring deviation:	10 K across the entire range: 0.15 K or 0.07% of span* in the range -50°C ... +250°C: 0.1 K or 0.07% of the measuring span*
output:	4-20mA (underflow linear drop of 4.0 ... 3.8 mA, linear increase of 20.0 ... 20.5 mA)
sensor break:	≤ 3.6 mA ("Low") or ≥ 21 mA ("High") can be selected
standard configuration	4mA = -50°C, 20mA = 150°C (wide temperature range can be parameterized)
electrical connection:	6x screw terminals 1.5mm ²
configuration:	PXU01 programming adapter Windows application for configuration ("PXU01")

* the larger value is valid

6.3 Technical drawings

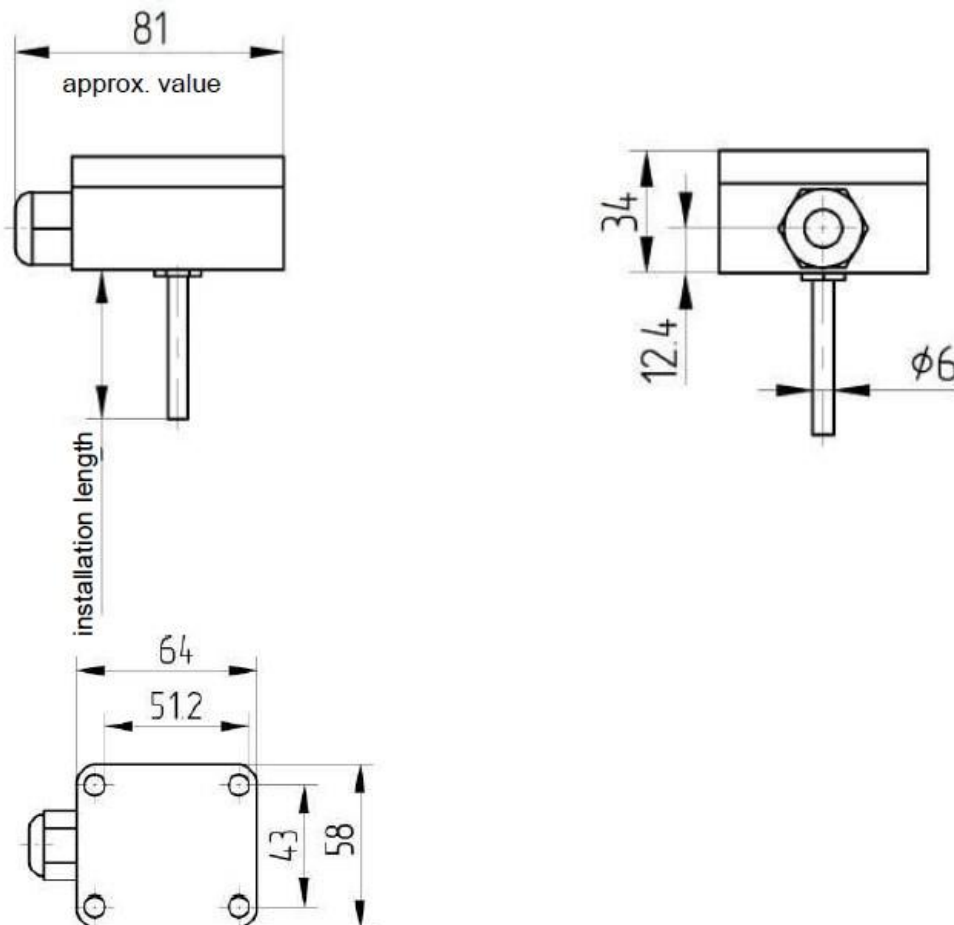

7. Dismounting, Return, Cleaning, Disposal

7.1 Dismounting



Residual media in dismantled instruments can result in a risk of personnel, the environment and equipment. Take sufficient precautionary measures.



There is a risk of burns. Let the instrument cool down sufficiently before dismantling. During dismantling there is a risk of dangerously hot pressure media escaping.

Only disconnect the resistance thermometer once the system has been depressurised.

7.2 Return



When returning the instrument, use the original packaging or a suitable package.

To avoid a damage, use for example antistatic plastic film, shock-absorbent material, a marking as highly sensitive measuring instrument.

7.3 Cleaning



Before cleaning the instrument disconnect the electrical connection. Clean the instrument with a moist cloth. Electrical connections must not come into contact with moisture. Wash or clean the dismantled instrument before returning it in order to protect personnel and the environment from exposure to residual media.

Residual media in dismantled instruments can result in a risk to persons, the environment and equipment. Take sufficient precautionary measures.

7.4 Disposal



Dispose instrument components and packaging materials in accordance with the respective waste treatment and disposal regulations of the region or country to which the sensor is supplied.