

temperature measurement

resistance thermometer WTR 310

features

- standard resistance thermometer with neck tube
- connection head made of stainless steel
- protective fitting on DIN 43 763
- available with tapered measuring point
- protective fitting pressed closed to connection head
- temperature resistance PT100 directly constructed in protective fitting
- electrical connection on board (clamps) or programmable measuring transducer
- specials on request

technical specifications

- protective fitting made of stainless steel 1.4571
- diameter 6 x 1 mm, other diameters on request
- process connection thread G 1/2" A
- temperature ranges: -50 °C to +400 °C (extended ranges on request)
- short reaction time

product benefits

The WTR 310 is a temperature sensor for use in liquid and vapour mediums. The integrated neck tube ensures decoupling from the process temperature, so that the sensor can be used reliably even at high temperatures. High-quality materials give this sensor a very high durability.



WTR 310-5-B-HR100-1A-V0-KMU



WTR 310-1-B-HR100-1A-V0-KMU

technical drawing

stainless steel head

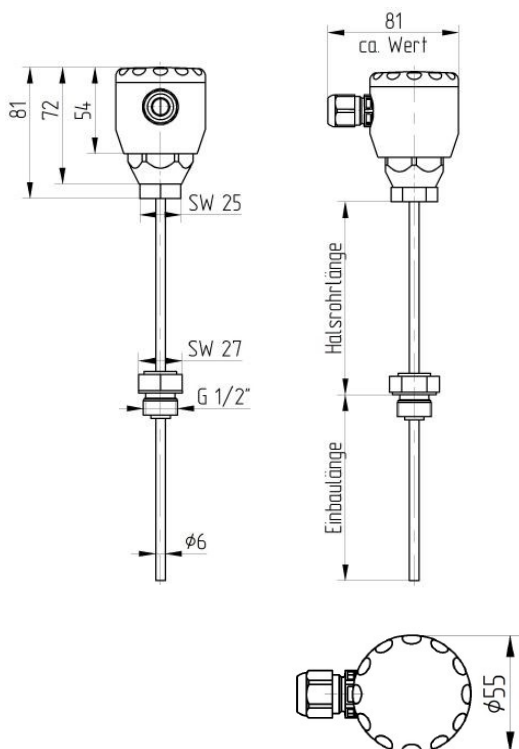

aluminiumhead

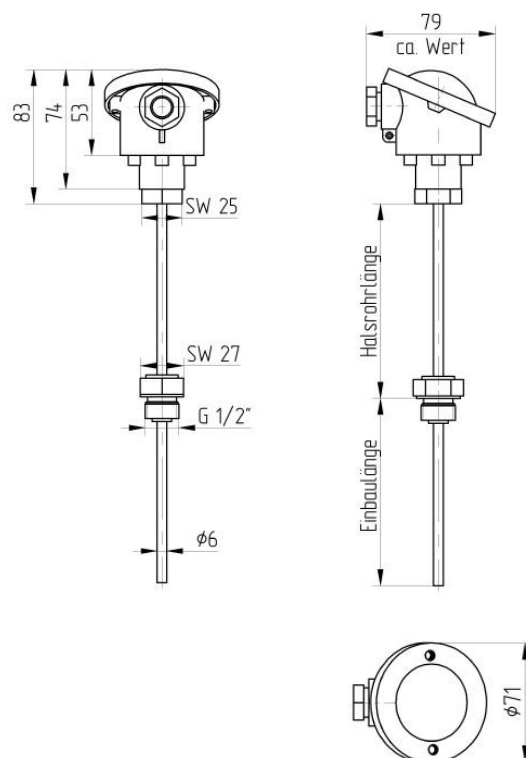

temperature measurement

order-code WTR 310...

order example: WTR 310-5-A-HR50-2A-V3-KMU (0-100 °C)

connection heads

-1	aluminiumhead standard, with screwing, protection class IP65
-5	stainless steel head standard with screw cap, with screwing, protection class IP69K
-6	stainless steel head standard with screw cap, with M12-plug, protection class IP69K
-J	aluminiumhead small, form J, protection class IP65 (not available with measuring transducer)

mounting length

-A	50 mm mounting length
-B	100 mm mounting length
-C	150 mm mounting length
-D	200 mm mounting length
-E	250 mm mounting length
-F	300 mm mounting length
-G	350 mm mounting length
-H	400 mm mounting length
-K	mounting length on customer`s request (please specify length)

neck tube length

-HRXXX	XXX neck tube length in mm (example HR50 = 50mm neck tube)
--------	--

type of sensor and tolerance

-1A	1xPT100 class A
-2A	2xPT100 class A
-1C	1xPT100 1/3 DIN
-2C	2xPT100 1/3 DIN
-KX	type of sensor and tolerance on customer`s request

tapered measuring point

-VO	without taper
-V3	tapered to 3 mm
-V4	tapered to 4 mm

optional

-KMU	with programmable measuring transducer (temperature range on request on preadjustment please specify)
------	---

accessories

welding sleeves

-99-000421	GEM 150, stainless steel weld-in sleeve, G1/2" inner thread, outer diameter 26mm, length sleeve 33mm
------------	--

M12-Connection wires

-101090	connection cable M12 angled, 4-pole, 5m PVC cable, grey
-101087	connection cable M12 straight, 4-pole, 5m PVC cable, grey